

SPECIFICATIONS

LHD HIGH LIFT

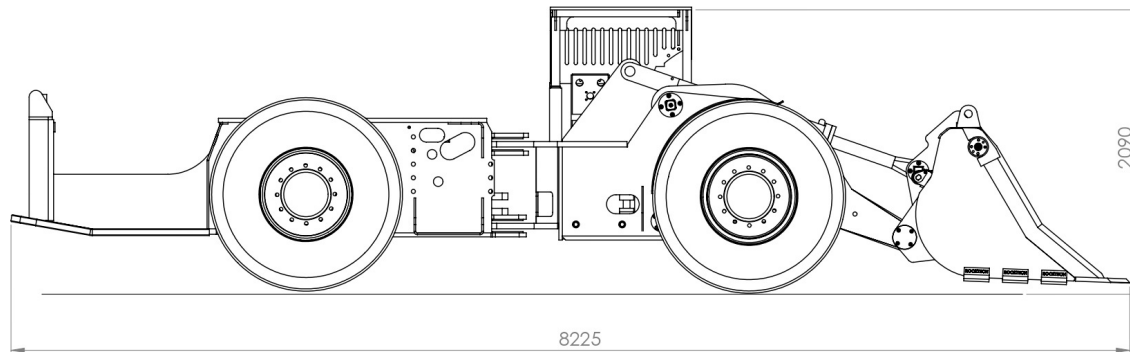

SPECIFICATIONS

- Machine Height 2090mm
- Machine Length 8225mm
- Inner Turning Radius. R2915
- Outer Turning Radius. R6134
- Centre Articulation 40
- Rear Oscillation 10
- Bucket Reach 2.5m
- Larger Bucket

ENGINE

- Type BF6L914
- Power Rating 92kW at 2 300rpm
- Torque 430Nm at 1 500rpm
- Fuel Consumption 220g/kWh
- Air Cleaner two stage

BRAKES

- Failsafe brakes

TYRES

- Tyre Size 17-5-25
- Designed to perform underground mine services
- Foam filled

ELECTRICAL SYSTEM

- 24V System
- Alternator 28V/55A
- Isolation switch lockout

SAFETY

- Fire Extinguisher
- Reverse Hooter
- Door Interlock
- Marker Lamps red/green

HYDRAULIC SYSTEM

- System pressure 28MPa
- Piston Pump
- Flow Rate 138 litres/min at 2 300rpm
- Hydraulic Tank Cap 170 litres

HYDRAULIC SYSTEM

- Fuel Tank Capacity 180 litres

